

# THERMOVAC-Transmitter

## TTR 91 N (S), TTR 96 N, TTR 911 N (C), TTR 916 N



THERMOVAC Transmitter TTR N analog (left); digital RS232 (middle), with Display (right)

The THERMOVAC Transmitters are active sensors using the unique MEMS-Pirani technology (Micro-Electro-Mechanical-Systems). They offer analog voltage output and the S-versions offer set point relays for improved process control. For chemical and aggressive applications, the C-versions are equipped with a Parylene HT®-coated sensor. The THERMOVAC series is also equipped with a LED-ring (360°) showing the status of the sensor.

The TTR 911 N and 916 N have a touch display and/or digital interfaces available.

### Advantages to the User

- Very robust MEMS-Pirani solid state sensor resilient to vibration and shock venting
- Extended measuring range up to  $5 \times 10^{-5}$  mbar and significantly higher accuracy compared to conventional sensors
- Reduced response times because of significantly improved signal processing
- High accuracy
- Individually temperature compensated to ensure stable measurements
- High reproducibility
- Measurement signal insensitive to mounting position
- Robust stainless steel housing
- Available with display for pressure units, set point parameters and operation status
- Available with up to three set point relays for improved process control
- Optional Computer interfaces: EtherCAT and RS 232
- Long tube version for reaching higher chamber bakeout temperatures
- LED ring to indicate status of the sensor

### Typical Applications

The THERMOVAC Transmitters offer a high degree of versatility. They are suited for applications in the medium and rough vacuum range.

Typical applications are:

- Analytical instrumentation
- Research and development
- Vacuum Drying
- Controlling of ionization gauges
- Activation of UHV gauges
- System process control
- Process industry
- Coated versions for improved chemical resistance
- General foreline vacuum measurement

### Sensor

The THERMOVAC transmitters' measurement principle is based on thermal conductivity. The transmitters are equipped with a MEMS-Pirani sensing cell that consists of a silicon chip with a heated resistive element.

The THERMOVAC transmitters with the coated MEMS-Pirani are well suited for harsh processes and therefore more robust than the uncoated versions. Built-in relays allow switching functions to be performed directly by the transmitter, without the need of a programmable control.

An integration of the transmitters in programmable control systems is facilitated by the linear characteristic, which can be defined by entering a simple equation into a PLC or computer.

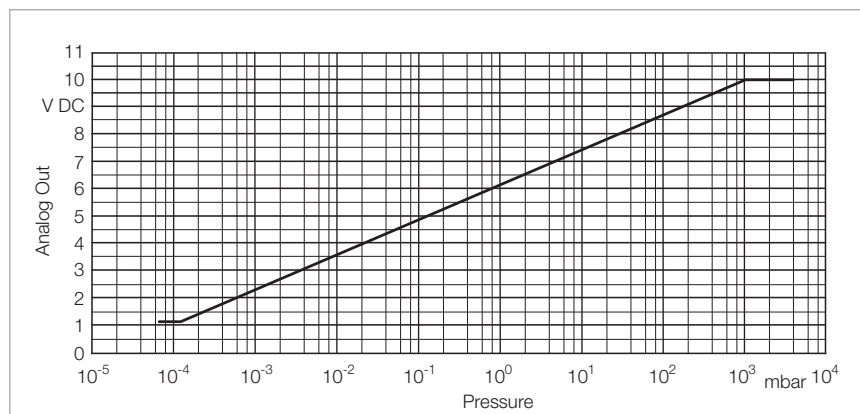

Characteristic of the THERMOVAC Transmitters TTR 91 N (S) / TTR 96 N and TTR 911 N (C) / TTR 916 N

Parylene HT® is a registered trademark of Speciality Coating Systems Inc.

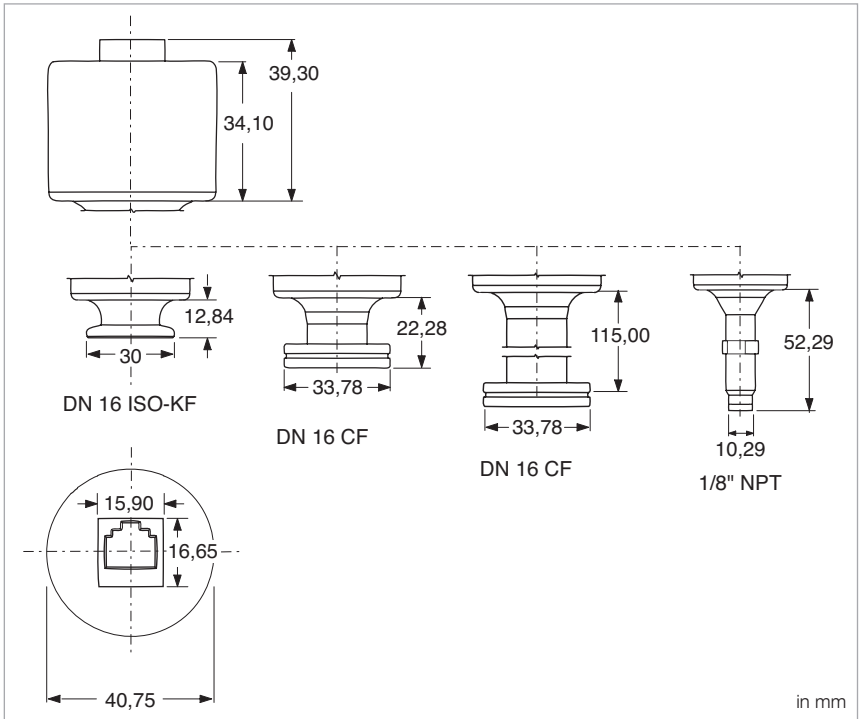

Dimensional drawings for the THERMOVAC Transmitters TTR 91 N (S) / TTR 96 N  
 (Middle left – DN 16 CF standard version, middle right backable with elongated flange)

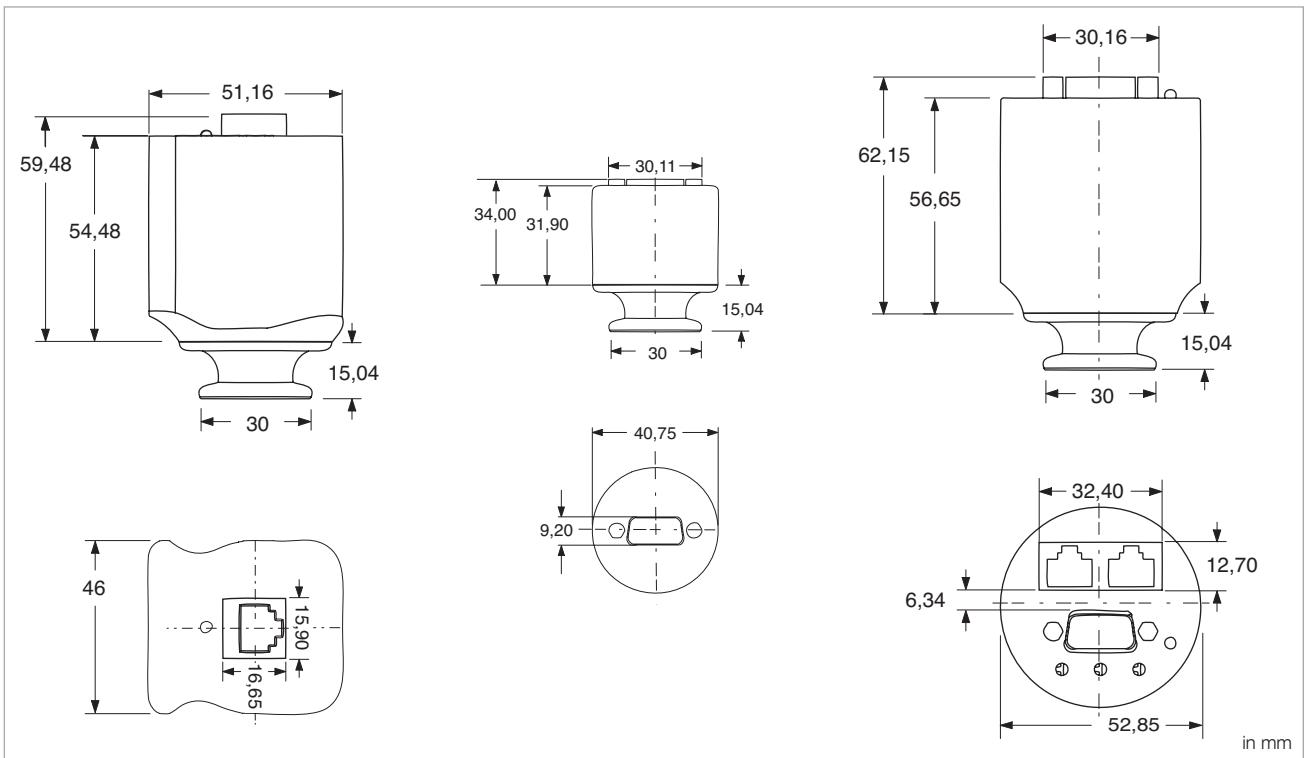

Dimensional drawings for the THERMOVAC Transmitters TTR 911 N (C) / TTR 916 N  
 left: with display, middle: with RS 232, right: with EtherCAT

## Technical Data

### THERMOVAC Transmitter TTR 91 N                      TTR 91 N S                      TTR 96 N S

Measurement range	mbar (Torr)	5.0 x 10 <sup>-5</sup> to Atmosphere (3.75 x 10 <sup>-5</sup> to Atmosphere)		
Measurement uncertainty of reading (typical) <sup>1)</sup>	mbar	5 x 10 <sup>-4</sup> to 1 x 10 <sup>-3</sup> ±10 % 1 x 10 <sup>-3</sup> to 100 ±5 % 100 to atm ±25 %		
Repeatability of reading (typical) <sup>1)</sup>	mbar	1 x 10 <sup>-3</sup> to 100 ±2 %		
Sensor		MEMS-Pirani	MEMS-Pirani	Coated MEMS-Pirani
Measurement principle		Thermal conductivity according to Pirani		
Supply voltage	V DC	9 – 30		
Power consumption	W	< 1.2		
Electrical connection		FCC 68, RJ45 (analog) / Sub-D 15 PIN (digital)		
Analog output	V DC	$V_{out} = \log_{10}(P_{mbar}) \times 1.286 + 6.143$ 0.61 to 10		
Resolution	bit	16		
Impedance	Ω	100		
Update rate	Hz	16		
Interfaces		FCC 68, RJ45 (analog) / RS232, EtherCAT, Profibus (digital)		
Set point				
Range	mbar (Torr)		2.7 x 10 <sup>-4</sup> to 1000 (2.0 x 10 <sup>-4</sup> to 750)	
Relay		0	2	2
Relay contact rating		1 A at 30 V AC/ DC, resistive load		
Relay contact resistance, max.	mΩ	100		
Relay contact endurance, min.		100 000		
1.0 A at 30 V DC load		2 000 000		
0.2 A at 30 V DC load				
Status indicators		LED-ring (360°)		
Max. cable length	m	100		
Overpressure limit (abs.)	bar	6 (10 bar for inert gases)		
Operating temperature range <sup>2)</sup>	°C (°F)	0 to 60 (32 to 140)		
Storage temperature range	°C (°F)	-20 to +65 (-4 to 149)		
Max. bakeout temperature	°C (°F)	85 (185), non-operating [bakeable version up to 250 (482)]		
Max. rel. humidity	% n.c.	≤ 95		
Installation orientation		Any		
Materials exposed to vacuum		304 stainless steel, Tin, Gold, Viton®		304 stainless steel, Viton®, Parylene-HT®
Dead volume (DN 16 ISO-KF), approx.	cm <sup>3</sup>	2.80		
Weight (DN 16 ISO-KF)	g	170		
Protection class	IP	40		
CE certification		EMC Directive 2014/30/EEC		
Controller type		DISPLAY ONE / TWO / THREE and GRAPHIX ONE / TWO / THREE		

<sup>1)</sup> Accuracy and repeatability are typical values measured with Nitrogen gas at ambient temperature after zero adjustment

<sup>2)</sup> There may be minimal deviation tolerances in the range of 40 – 60 °C

## Ordering Information

## THERMOVAC Transmitter TTR 91 N (S) / TTR 96 N

	Part No.
Without switching threshold	
TTR 91 N, DN 16 ISO-KF	<b>230035V02</b>
TTR 91 N, 1/8" NPT	<b>230038V02</b>
TTR 91 N, DN 16 CF	<b>230036V02</b>
TTR 91 N, DN 16 CF, Flange extended bakeable up to 250 °C (482 °F)	<b>230037V02</b>
With switching threshold	
TTR 91 N, DN 16 ISO-KF, 2SP	<b>230040V02</b>
TTR 91 N, 1/8" NPT, 2SP	<b>230043V02</b>
TTR 96 N C, DN 16 ISO-KF, 2SP, Parylene coated	<b>230045V02</b>
TTR 96 NC, DN 16 CF, 2SP, Flange extended bakeable up to 250 °C (482 °F), Parylene coated	<b>230047V02</b>
Calibration	see chapter "Miscellaneous", para. "Leybold Calibration Service"
Operating Units	
DISPLAY ONE	<b>230 001</b>
DISPLAY TWO	<b>230 024</b>
DISPLAY THREE	<b>230 025</b>
GRAPHIX ONE	<b>230680V01</b>
GRAPHIX TWO	<b>230681V01</b>
GRAPHIX THREE	<b>230682V01</b>
Connection cable, FCC 68 on both ends <sup>1)</sup>	<b>Type A</b>
5 m	<b>124 26</b>
10 m	<b>230 012</b>
15 m	<b>12427</b>
20 m	<b>12428</b>
30 m	<b>12429</b>
50 m	<b>12431</b>
75 m	<b>12432</b>
100 m	<b>12433</b>
Optional accessories	
Spiral tube DN 16 ISO-KF	<b>230082</b>
Connection cable, RS 232 <sup>1)</sup>	<b>Type G</b>
5 m	<b>230550V01</b>
10 m	<b>230551V01</b>
15 m	<b>230552V01</b>
20 m	<b>230553V01</b>

<sup>1)</sup> See chapter "Connection cables for Active Sensors"

## Technical Data

### THERMOVAC Transmitter TTR 911 N (C/S) / TTR 916 N

Measurement range	mbar (Torr)	5.0 x 10 <sup>-5</sup> to Atmosphere (3.75 x 10 <sup>-5</sup> to Atmosphere) 1.0 x 10 <sup>-5</sup> to Atmosphere (0.75 x 10 <sup>-5</sup> to Atmosphere) [RS 232 / Display]
Measurement uncertainty of reading <sup>1)</sup>	mbar	5.0 x 10 <sup>-4</sup> to 1.0 x 10 <sup>-3</sup> ±10 % 1.0 x 10 <sup>-3</sup> to 100 ±5 % 100 to atm ±25 %
Repeatability of reading <sup>1)</sup>	mbar	1 x 10 <sup>-3</sup> to 100 ±2 %
Sensor		MEMS-Pirani
Measurement principle		Thermal conductivity according to Pirani
Supply voltage	V DC	9 - 30
Power consumption	W	< 1.2
Electrical connection		FCC 68, RJ45 (analog) / Sub-D 15 PIN (digital)
Analog output	V DC	$V_{out} = \log_{10}(P_{mbar}) \times 1.286 + 6.143$ 0.61 to 10
Resolution	bit	16
Impedance	Ω	100
Update rate	Hz	16
Interfaces		FCC 68, RJ 45 (analog) / RS 232, EtherCAT, Profibus (digital)
Set point Range	mbar (Torr)	1.0 x 10 <sup>-4</sup> to 1000 (0.75 x 10 <sup>-5</sup> to 750) 2.7 x 10 <sup>-4</sup> to 1000 (2.0 x 10 <sup>-4</sup> to 750) [RS 232 / Display]
Relay		2 [Profibus / Display] / 2 [RS 232]
Relay contact rating		1 A at 30 V AC/ DC, resistive load
Relay contact resistance, max.	mΩ	100
Relay contact endurance, min.		100 000
1.0 A at 30 V DC load		2 000 000
0.2 A at 30 V DC load		
Status indicators		LED-ring (360°)
Max. cable length	m	100
Overpressure limit (abs.)	bar	6 (10 bar for inert gases)
Operating temperature range <sup>2)</sup>	°C (°F)	0 to 60 (32 to 140)
Storage temperature range	°C (°F)	-20 to +65 (-4 to 149)
Max. bakeout temperature	°C (°F)	85 (185), non-operating
Max. rel. humidity	% n.c.	0 – 95
Installation orientation		Any
Materials exposed to vacuum		304 stainless steel, Tin, Gold, Viton®, Parylene-HT® (coated)
Dead volume (DN 16 ISO-KF), approx.	cm <sup>3</sup>	2.80
Weight (DN 16 ISO-KF, RS 232 w/o Display)	g	168
Protection class	IP	40
CE certification		EMC Directive 2014/30/EEC
Controller type		DISPLAY ONE / TWO / THREE and GRAPHIX ONE / TWO / THREE

<sup>1)</sup> Accuracy and repeatability are typical values measured with Nitrogen gas at ambient temperature after zero adjustment

<sup>2)</sup> There may be minimal deviation tolerances in the range of 40 – 60 °C

## Ordering Information

## THERMOVAC Transmitter TTR 911 N (C/S) / TTR 916 N

	Part No.
TTR 911 N, DN 16 ISO-KF, EtherCAT	<b>230700V02</b>
TTR 911 N C, DN 16 ISO-KF, EtherCAT, Parylene coated	<b>230701V02</b>
TTR 911 N S, DN 16 ISO-KF, RS 232	<b>89660V02</b>
TTR 911 N, DN 16 ISO-KF, with display, FCC 68 / RJ 45	<b>89654V02</b>
TTR 916 N C, DN 16 ISO-KF, Parylene coated, FCC 68 / RJ 45	<b>89656V02</b>
Replacement sensor, DN 16 ISO-KF TTR 911 N, without Parylene coating	<b>230650V02</b>
TTR 916 N SC, TTR 911 NC, with Parylene coating	<b>230651V02</b>
Calibration	See Section "Miscellaneous", paragraph "Leybold calibration service"
Operating Units	
DISPLAY ONE	<b>230 001</b>
DISPLAY TWO	<b>230 024</b>
DISPLAY THREE	<b>230 025</b>
GRAPHIX ONE	<b>230680V01</b>
GRAPHIX TWO	<b>230681V01</b>
GRAPHIX THREE	<b>230682V01</b>
Connection cable, FCC 68 on both ends	<b>Type A</b>
5 m	<b>124 26</b>
10 m	<b>230012</b>
15 m	<b>12427</b>
20 m	<b>12428</b>
30 m	<b>12429</b>
50 m	<b>12431</b>
75 m	<b>12432</b>
100 m	<b>12433</b>
Optional accessories	
Spiral tube DN 16 ISO-KF	<b>230 082</b>
RS232 / USB Converter for setpoint definition of RS232 gauges	<b>230399V02</b>